

GRAN MAX

シリーズ

建設機械・産業車両を始め、
様々な産業用油圧機器にご使用頂けるホースとして、
従来のIB・HD・SPシリーズを統一した、
画期的な統合ホース・金具シリーズです。

IBG 35 IBG 70

構造

内面ゴム: 耐油性合成ゴム
補強層: 硬鋼線
外面ゴム: 耐油・耐候性合成ゴム

適用流体

一般鉱物系作動油

流体温度範囲

-40℃~+100℃

ホース構造・補強層

1W/B

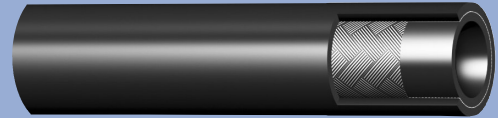

2W/B



3W/B

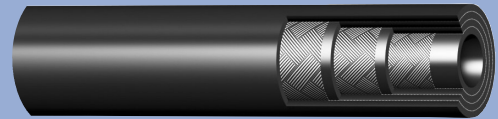

IBG 35

サイズ	補強層	内径 mm	外径 mm	最高使用圧力 MPa	最小破壊圧力 MPa	最小曲げ半径 mm	概略重量 g/m
32	1W/B	31.8	41.1	3.5	14	210	930
38	1W/B	38.1	47.4	3.5	14	240	1140
50	1W/B	50.8	61.0	3.5	14	310	1680

IBG 70

サイズ	補強層	内径 mm	外径 mm	最高使用圧力 MPa	最小破壊圧力 MPa	最小曲げ半径 mm	概略重量 g/m
6	1W/B	6.3	13.1	7	28	50	210
9	1W/B	9.5	16.3	7	28	65	270
12	1W/B	12.7	19.5	7	28	70	380
15	1W/B	15.9	23.8	7	28	120	490
19	1W/B	19.0	27.5	7	28	130	630
25	1W/B	25.4	34.3	7	28	170	810
32	2W/B	31.8	43.2	7	28	220	1450
38	2W/B	38.1	50.1	7	28	260	1840
50	2W/B	50.8	63.3	7	28	320	2510
65	3W/B	63.5	82.4	7	28	650	4850

IBG 35 IBG 70

サイズ	B	C	D	H	L				ねじ R	概略 重量g
6	13	6	4.2	19	48				1/4	50
9	15	6	7.0	22	50				3/8	80
12	18	8	9.5	27	58				1/2	130
15	20	10	16.0	30	66				3/4	200
19	20	10	16.1	30	69				3/4	220
25	22	10	21.8	36	75				1	310
32	25	13	27.0	46	82				1 1/4	500
38	25	14	31.8	50	90				1 1/2	800
50	30	19	42.0	65	105				2	1200
65	33	18	54.0	85	170				2 1/2	2900

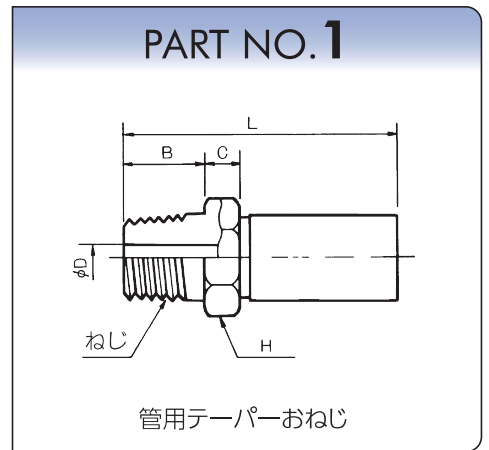

サイズ	B	C	D	E	H	L			ねじ G	概略 重量g
6	13	6	4.2	9.5	19	48			1/4	50
9	15	6	7.0	12.5	22	50			3/8	80
12	18	8	9.5	16.0	27	58			1/2	130
15	20	10	16.0	21.5	30	66			3/4	200
19	20	10	16.1	21.5	30	69			3/4	220
25	22	10	21.8	27.5	36	75			1	310
32	25	13	27.0	36.0	46	82			1 1/4	500
38	25	14	31.8	42.0	50	90			1 1/2	800
50	30	19	42.0	54.0	65	105			2	1200
65	37	18	54.0	66.0	85	174			2 1/2	2900

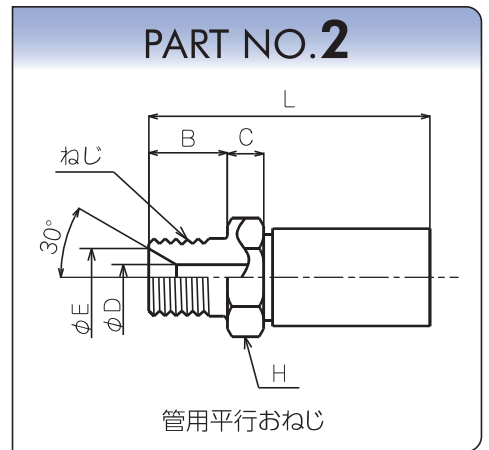

サイズ	A	B	C	D	E	H1	H2	L	ねじ G	概略 重量g
6	8.5	16.0	6	4.2	9.5	19	19	51	1/4	70
9	9.5	19.0	6	7.0	13.0	22	22	54	3/8	100
12	11.0	21.5	8	9.5	16.0	27	27	62	1/2	170
15	12.5	23.0	10	16.0	22.0	36	30	69	3/4	250
19	12.5	23.0	10	16.0	22.0	36	30	72	3/4	260
25	12.5	25.5	10	21.8	28.0	41	36	79	1	360
32	15.5	30.5	13	27.0	36.0	50	46	88	1 1/4	610
38	16.5	33.5	14	31.8	42.0	55	50	99	1 1/2	790
50	18.0	37.0	19	42.0	54.0	70	65	112	2	1400
65	30.5	50.0	18	54.0	70.0	85	85	188	2 1/2	3400

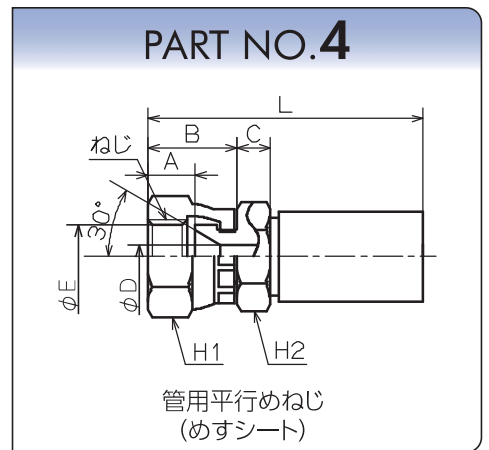

サイズ	A	B	C	D	E	H1	H2	L	ねじ G	概略 重量g
6	5.5	16.0	6	4.2	7.5	19	19	51	1/4	70
9	6.5	19.0	6	7.0	10.0	22	22	54	3/8	100
12	8.5	21.5	8	9.5	13.0	27	27	62	1/2	170
15	9.0	23.0	10	16.0	19.0	36	30	69	3/4	250
19	9.0	23.0	10	16.1	19.0	36	30	72	3/4	260
25	9.5	25.5	10	21.8	24.7	41	36	79	1	360
32	12.5	30.5	13	27.0	32.0	50	46	88	1 1/4	610
38	12.5	33.5	14	31.8	38.0	55	50	99	1 1/2	790
50	15.0	37.0	19	42.0	49.0	70	65	112	2	1400
65	21.5	50.0	18	54.0	60.0	85	85	188	2 1/2	3400

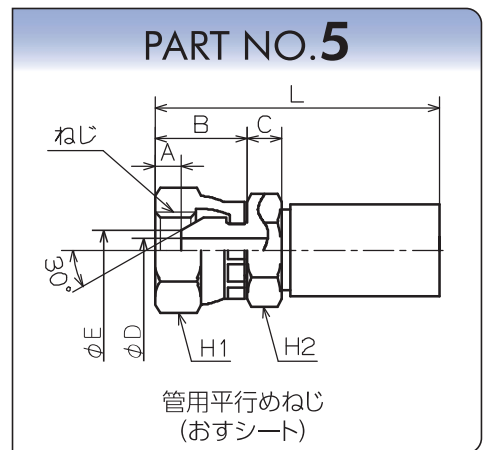

IBG 35 IBG 70

サイズ	A	D	E	F	H1	H2	J	L	ねじ G	概略 重量g
6	8.5	4.2	9.5	24	19	-	44	71	1/4	70
9	9.5	6.5	13.0	26	22	-	49	76	3/8	110
12	10.5	9.5	16.0	32	27	-	56	86	1/2	190
15	12.5	13.6	22.0	38	36	30	70	104	3/4	360
19	12.5	17.0	22.0	38	36	30	70	107	3/4	380
25	12.5	21.0	28.0	47	41	36	80	121	1	550
32	15.5	28.0	36.0	65	50	46	124	166	1 1/4	1000
38	16.5	32.8	42.0	76	55	50	130	179	1 1/2	1650
50	18.0	42.0	54.0	85	70	65	169	239	2	3100

PART NO.454

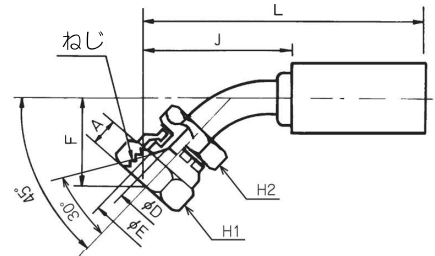

45° ベンドフィッティング
(めすシート)

サイズ	A	D	E	F	H1	H2	J	L	ねじ G	概略 重量g
6	8.5	4.2	9.5	44	19	-	26	53	1/4	70
9	9.5	6.5	13.0	47	22	-	34	61	3/8	120
12	10.5	9.5	16.0	55	27	-	37	67	1/2	190
15	12.5	13.6	22.0	70	36	30	50	84	3/4	400
19	12.5	17.0	22.0	70	36	30	50	87	3/4	420
25	12.5	21.0	28.0	87	41	36	59	100	1	660
32	15.5	28.0	36.0	110	50	46	91	133	1 1/4	1100
38	16.5	32.8	42.0	143	55	50	117	166	1 1/2	1500
50	18.0	42.0	54.0	168	70	65	151	205	2	3800

PART NO.904

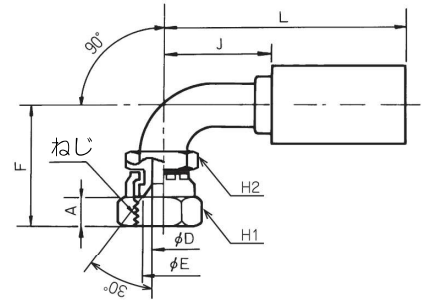

90° ベンドフィッティング
(めすシート)

サイズ	A	D	E	F	H1	H2	J	L	ねじ G	概略 重量g
6	4.5	4.2	7.0	24	19	-	44	71	1/4	70
9	5.5	6.5	9.7	26	22	-	49	76	3/8	110
12	7.0	9.5	13.0	32	27	-	56	86	1/2	190
15	9.0	13.6	19.0	38	36	30	70	104	3/4	400
19	9.0	17.0	19.0	38	36	30	70	107	3/4	420
25	9.5	21.0	24.0	47	41	36	80	121	1	660
32	12.5	28.0	32.0	65	50	46	124	166	1 1/4	1000
38	12.5	32.8	38.0	76	55	50	145	194	1 1/2	1650
50	15.0	42.0	49.0	85	70	65	185	239	2	2800

PART NO.455

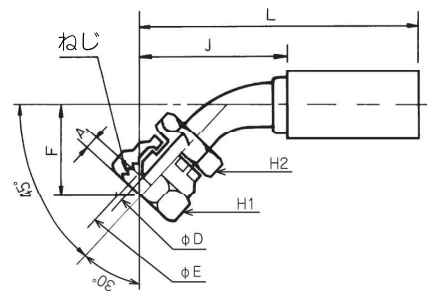

45° ベンドフィッティング
(おすシート)

サイズ	A	D	E	F	H1	H2	J	L	ねじ G	概略 重量g
6	4.5	4.2	7.0	44	19	-	26	53	1/4	70
9	5.5	6.5	9.7	47	22	-	34	61	3/8	120
12	7.0	9.5	13.0	55	27	-	37	67	1/2	190
15	9.0	13.6	19.0	70	36	30	50	84	3/4	400
19	9.0	17.0	19.0	70	36	30	50	87	3/4	420
25	9.5	21.0	24.0	87	41	36	59	100	1	660
32	12.5	28.0	32.0	110	50	46	91	133	1 1/4	1100
38	12.5	32.8	38.0	143	55	50	117	166	1 1/2	1500
50	15.0	42.0	49.0	168	70	65	151	205	2	3800

PART NO.905

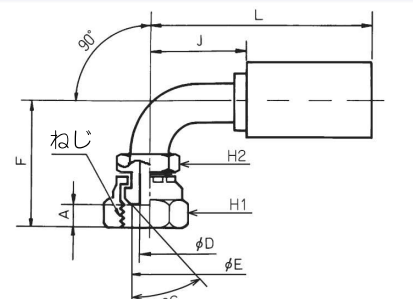

90° ベンドフィッティング
(おすシート)

IBG 35 IBG 70

サイズ	A	B	D	G	J	L				概略重量g
12	30.2	25.46	9.0	6.7	52	82				150
15	38.1	31.81	12.0	6.7	54	88				270
19	38.1	31.81	15.0	6.7	54	91				250
25	44.5	39.68	20.0	8.0	65	106				420
32	50.8	44.51	26.0	8.0	68	110				670
38	60.3	53.84	31.8	8.0	70	119				820
50	71.4	63.37	42.0	9.5	80	134				1450
65	84.1	76.20	54.0	9.5	48	167				2700

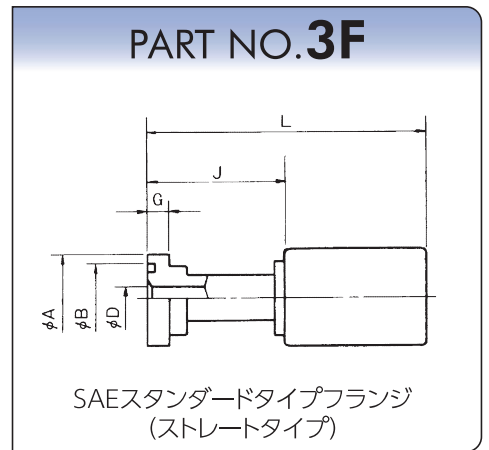

サイズ	A	B	D	F	G	J	L			概略重量g
12	30.2	25.46	10.5	22	6.7	51	81			160
15	38.1	31.81	13.6	26	6.7	64	98			280
19	38.1	31.81	17.0	26	6.7	64	101			300
25	44.5	39.68	21.0	28	8.0	76	117			420
32	50.8	44.51	27.0	32	8.0	90	132			660
38	60.3	53.84	32.5	43	8.0	108	157			1000
50	71.4	63.37	43.5	55	9.5	156	210			1950
65	84.1	76.20	52.3	65	9.5	155	274			3300

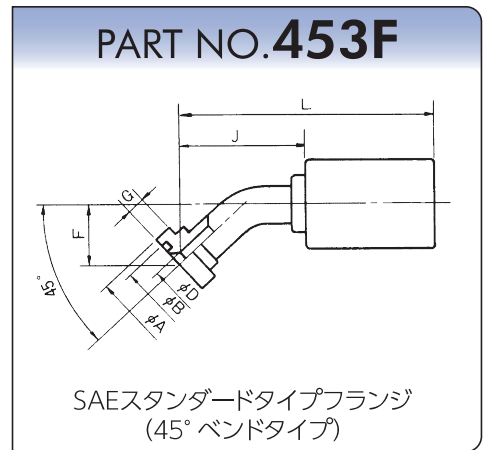

サイズ	A	B	D	F	G	J	L			概略重量g
12	30.2	25.46	10.5	43	6.7	52	82			180
15	38.1	31.81	13.6	56	6.7	50	84			280
19	38.1	31.81	17.0	56	6.7	50	87			300
25	44.5	39.68	21.0	63	8.0	59	100			520
32	50.8	44.51	27.0	71	8.0	91	133			790
38	60.3	53.84	32.5	92	8.0	117	166			1240
50	71.4	63.37	43.5	125	9.5	151	205			3250
65	84.1	76.20	52.3	135	9.5	134	253			3600

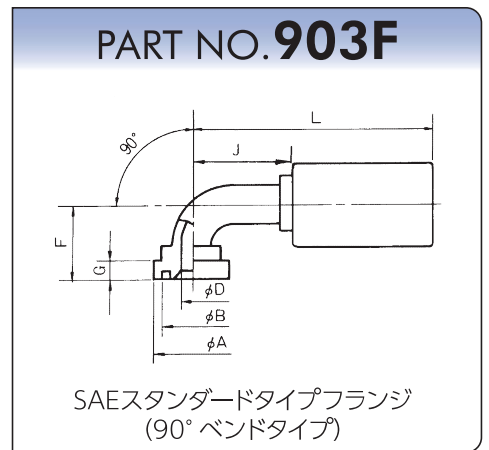

IBG 140

構造

内面ゴム： 耐油性合成ゴム
 補強層： 硬鋼線
 外面ゴム： 耐油・耐候性合成ゴム

適用流体

一般鉱物系作動油

流体温度範囲

-40℃～+100℃

ホース構造・補強層

1W/B

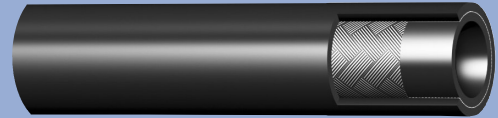

4W/S



2W/B

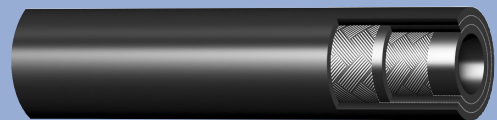

IBG 140

サイズ	補強層	内径 mm	外径 mm	最高使用圧力 MPa	最小破壊圧力 MPa	最小曲げ半径 mm	概略重量 g/m
6	1W/B	6.3	13.1	14	56	55	220
9	1W/B	9.5	16.4	14	56	70	290
12	1W/B	12.7	19.5	14	56	75	390
15	2W/B	15.9	25.0	14	56	110	720
19	2W/B	19.0	28.4	14	56	130	900
25	2W/B	25.4	34.8	14	56	170	1100
32	4W/S	31.8	44.5	14	56	230	2470
38	4W/S	38.1	53.6	14	56	270	3250
50	4W/S	50.8	66.7	14	56	350	4510

IBG 140

サイズ	B	C	D	H	L				ねじ R	概略 重量g
6	13	6	4.2	19	48				1/4	50
9	15	6	7.0	22	50				3/8	80
12	18	8	9.5	27	58				1/2	130
15	20	10	16.0	30	66				3/4	210
19	20	10	16.1	30	69				3/4	230
25	22	10	21.8	36	75				1	320
32	25	13	27.0	46	108				1 1/4	720
38	25	14	31.8	50	119				1 1/2	1150
50	30	19	42.0	65	143				2	2100

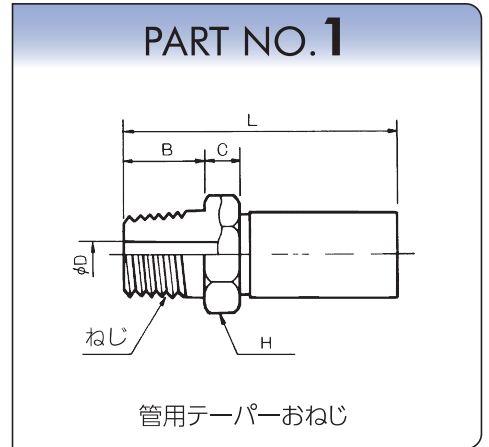

サイズ	B	C	D	E	H	L			ねじ G	概略 重量g
6	13	6	4.2	9.5	19	48			1/4	50
9	15	6	7.0	12.5	22	50			3/8	80
12	18	8	9.5	16.0	27	58			1/2	130
15	20	10	16.0	21.5	30	66			3/4	210
19	20	10	16.1	21.5	30	69			3/4	230
25	22	10	21.8	27.5	36	75			1	320
32	25	13	27.0	36.0	46	108			1 1/4	720
38	25	14	31.8	42.0	50	119			1 1/2	1150
50	30	19	42.0	54.0	65	143			2	2100

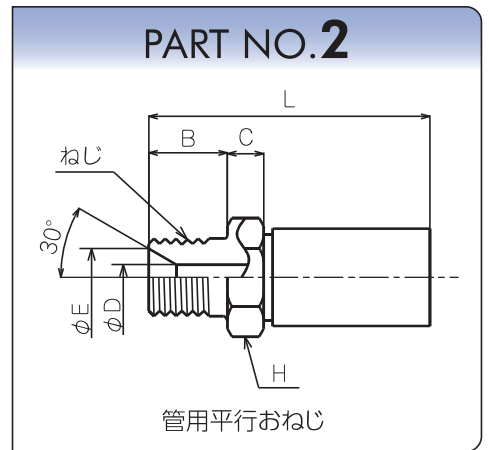

サイズ	A	B	C	D	E	H1	H2	L	ねじ G	概略 重量g
6	8.5	16.0	6	4.2	9.5	19	19	51	1/4	70
9	9.5	19.0	6	7.0	13.0	22	22	54	3/8	100
12	11.0	21.5	8	9.5	16.0	27	27	62	1/2	170
15	12.5	23.0	10	16.0	22.0	36	30	69	3/4	250
19	12.5	23.0	10	16.0	22.0	36	30	72	3/4	270
25	12.5	25.5	10	21.8	28.0	41	36	79	1	370
32	15.5	30.5	13	27.0	36.0	50	46	114	1 1/4	780
38	16.5	33.5	14	31.8	42.0	55	50	128	1 1/2	1250
50	18.0	37.0	19	42.0	54.0	70	65	150	2	2200

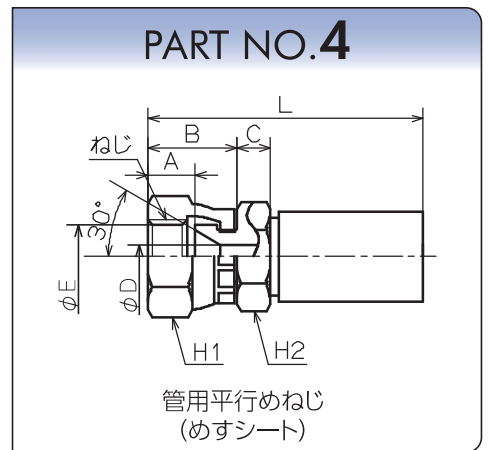

サイズ	A	B	C	D	E	H1	H2	L	ねじ G	概略 重量g
6	5.5	16.0	6	4.2	7.5	19	19	51	1/4	70
9	6.5	19.0	6	7.0	10.0	22	22	54	3/8	100
12	8.5	21.5	8	9.5	13.0	27	27	62	1/2	170
15	9.0	23.0	10	16.0	19.0	36	30	69	3/4	250
19	9.0	23.0	10	16.1	19.0	36	30	72	3/4	270
25	9.5	25.5	10	21.8	24.7	41	36	79	1	370
32	12.5	30.5	13	27.0	32.0	50	46	114	1 1/4	780
38	12.5	33.5	14	31.8	38.0	55	50	128	1 1/2	1250
50	15.0	37.0	19	42.0	49.0	70	65	150	2	2200

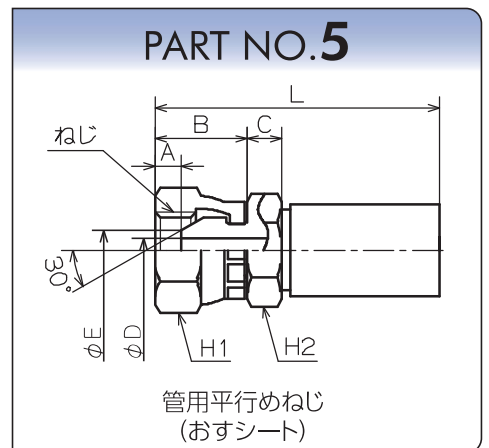

IBG 140

サイズ	A	D	E	F	H1	H2	J	L	ねじ G	概略 重量g
6	8.5	4.2	9.5	24	19	-	44	71	1/4	70
9	9.5	6.5	13.0	26	22	-	49	76	3/8	110
12	10.5	9.5	16.0	32	27	-	56	86	1/2	190
15	12.5	13.6	22.0	38	36	30	70	104	3/4	380
19	12.5	17.0	22.0	38	36	30	70	107	3/4	400
25	12.5	21.0	28.0	47	41	36	80	121	1	570

PART NO.454

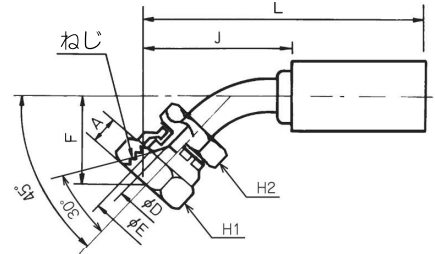

45° ベンドフィッティング
(めすシート)

サイズ	A	D	E	F	H1	H2	J	L	ねじ G	概略 重量g
6	8.5	4.2	9.5	44	19	-	26	53	1/4	70
9	9.5	6.5	13.0	47	22	-	34	61	3/8	120
12	10.5	9.5	16.0	55	27	-	37	67	1/2	190
15	12.5	13.6	22.0	70	36	30	50	84	3/4	420
19	12.5	17.0	22.0	70	36	30	50	87	3/4	440
25	12.5	21.0	28.0	87	41	36	59	100	1	680

PART NO.904

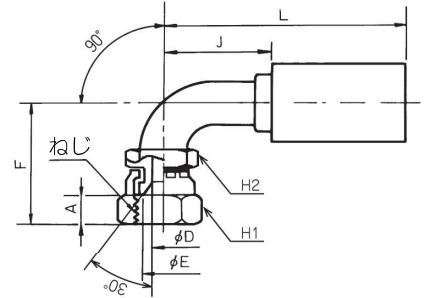

90° ベンドフィッティング
(めすシート)

サイズ	A	D	E	F	H1	H2	J	L	ねじ G	概略 重量g
6	4.5	4.2	7.0	24	19	-	44	71	1/4	70
9	5.5	6.5	9.7	26	22	-	49	76	3/8	110
12	7.0	9.5	13.0	32	27	-	56	86	1/2	190
15	9.0	13.6	19.0	38	36	30	70	104	3/4	380
19	9.0	17.0	19.0	38	36	30	70	107	3/4	400
25	9.5	21.0	24.0	47	41	36	80	121	1	570

PART NO.455

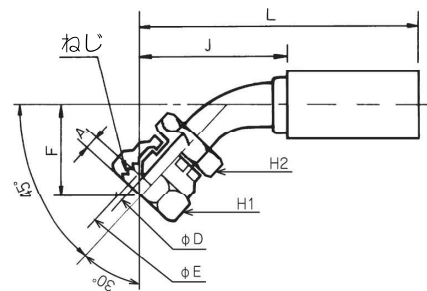

45° ベンドフィッティング
(おすシート)

サイズ	A	D	E	F	H1	H2	J	L	ねじ G	概略 重量g
6	4.5	4.2	7.0	44	19	-	26	53	1/4	70
9	5.5	6.5	9.7	47	22	-	34	61	3/8	120
12	7.0	9.5	13.0	55	27	-	37	67	1/2	190
15	9.0	13.6	19.0	70	36	30	50	84	3/4	420
19	9.0	17.0	19.0	70	36	30	50	87	3/4	440
25	9.5	21.0	24.0	87	41	36	59	100	1	680

PART NO.905

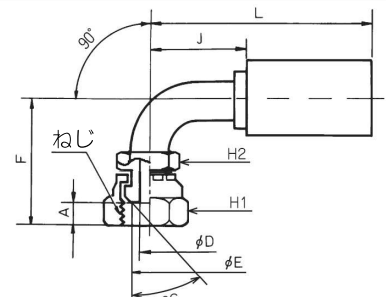

90° ベンドフィッティング
(おすシート)

IBG 140

サイズ	A	B	D	G	J	L				概略重量g
12	30.2	25.46	9.0	6.7	52	82				150
15	38.1	31.81	12.0	6.7	54	88				270
19	38.1	31.81	15.0	6.7	54	91				250
25	44.5	39.68	20.0	8.0	65	106				420
32	50.8	44.51	26.0	8.0	85	153				900
38	60.3	53.84	31.8	8.0	87	165				1500
50	71.4	63.37	42.0	9.5	101	193				2600

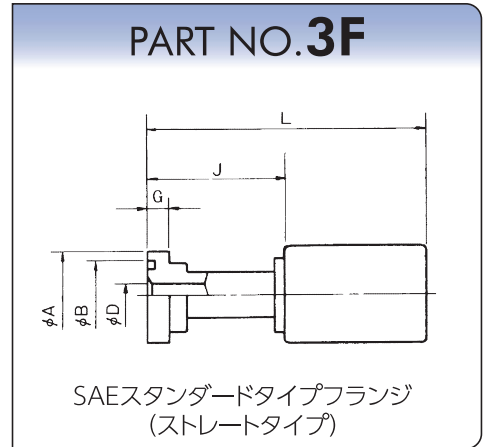

サイズ	A	B	D	F	G	J	L			概略重量g
12	30.2	25.46	10.5	22	6.7	51	81			160
15	38.1	31.81	13.6	26	6.7	64	98			280
19	38.1	31.81	17.0	26	6.7	64	101			300
25	44.5	39.68	21.0	28	8.0	76	117			420
32	50.8	44.51	27.0	32	8.0	91	159			700
38	60.3	53.84	32.5	52	8.0	140	218			1500
50	71.4	63.37	43.5	58	9.5	148	240			2800

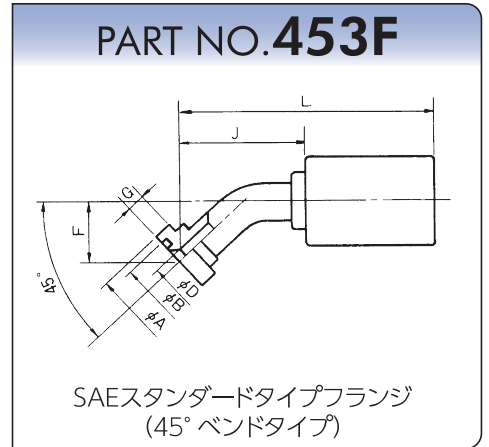

サイズ	A	B	D	F	G	J	L			概略重量g
12	30.2	25.46	10.5	43	6.7	52	82			180
15	38.1	31.81	13.6	56	6.7	50	84			280
19	38.1	31.81	17.0	56	6.7	50	87			300
25	44.5	39.68	21.0	63	8.0	59	100			520
32	50.8	44.51	27.0	71	8.0	91	159			1000
38	60.3	53.84	32.5	112	8.0	115	193			1800
50	71.4	63.37	43.5	127	9.5	140	232			3900

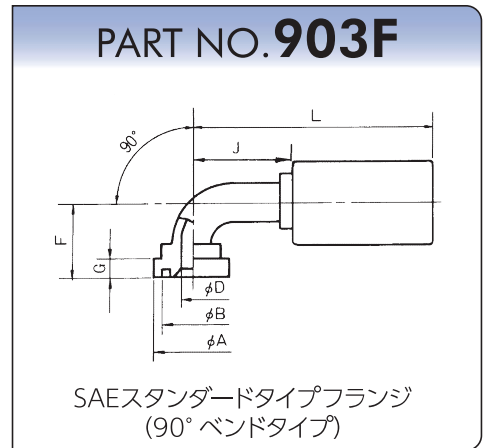

GRAN MAXシリーズ

IBG 210

構造

内面ゴム： 耐油性合成ゴム
補強層： 硬鋼線
外面ゴム： 耐油・耐候性合成ゴム

適用流体

一般鉱物系作動油

流体温度範囲

-40℃～+100℃

ホース構造・補強層

1W/B

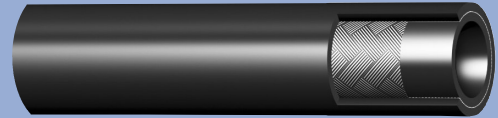

2W/B



4W/S

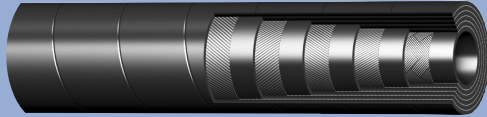

IBG 210

サイズ	補強層	内径 mm	外径 mm	最高使用圧力 MPa	最小破壊圧力 MPa	最小曲げ半径 mm	概略重量 g/m
6	1W/B	6.3	13.2	21	84	60	240
9	2W/B	9.5	17.3	21	84	80	470
12	2W/B	12.7	21.0	21	84	90	590
15	2W/B	15.9	25.0	21	84	120	730
19	2W/B	19.0	28.4	21	84	140	910
25	2W/B	25.4	34.9	21	84	180	1240
32	4W/S	31.8	44.5	21	84	230	2470
38	4W/S	38.1	53.6	21	84	310	3250
50	4W/S	50.8	66.7	21	84	430	4560
65	4W/S	63.5	82.2	21	84	650	6460

IBG 210

サイズ	B	C	D	H	L				ねじ R	概略重量g
6	13	6	4.2	19	48				1/4	50
9	15	6	7.0	22	50				3/8	90
12	18	8	9.5	27	58				1/2	150
15	20	10	16.0	30	66				3/4	210
19	20	10	16.1	30	69				3/4	230
25	22	12	21.8	36	85				1	320
32	25	13	27.0	46	108				1 1/4	720
38	25	14	31.8	50	119				1 1/2	1150
50	30	19	42.0	65	143				2	2100
65	33	18	54.0	85	170				2 1/2	3000

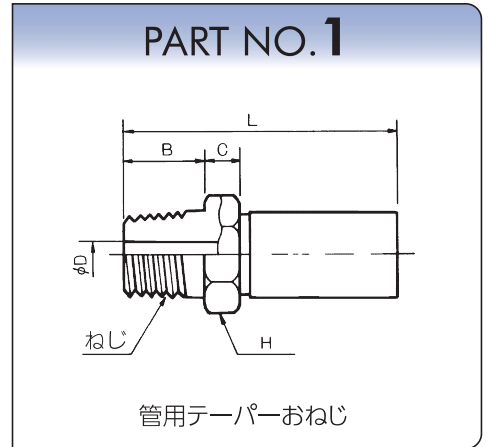

サイズ	B	C	D	E	H	L			ねじ G	概略重量g
6	13	6	4.2	9.5	19	48			1/4	50
9	15	6	7.0	12.5	22	50			3/8	90
12	18	8	9.5	16.0	27	58			1/2	150
15	20	10	16.0	21.5	30	66			3/4	210
19	20	10	16.1	21.5	30	69			3/4	230
25	22	12	21.8	27.5	36	85			1	320
32	25	13	27.0	36.0	46	108			1 1/4	720
38	25	14	31.8	42.0	50	119			1 1/2	1150
50	30	19	42.0	54.06	65	143			2	2100
65	37	18	54.0	6.0	85	174			2 1/2	3000

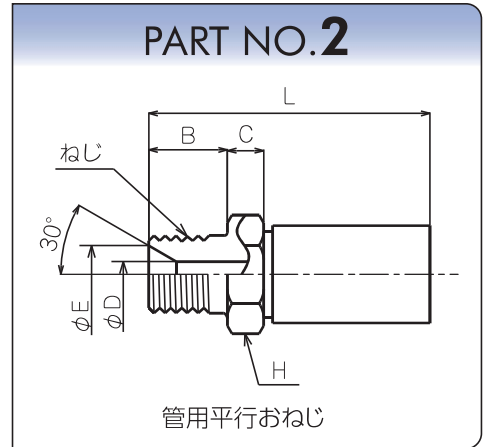

サイズ	A	B	C	D	E	H1	H2	L	ねじ G	概略重量g
6	8.5	16.0	6	4.2	9.5	19	19	51	1/4	70
9	9.5	19.0	6	7.0	13.0	22	22	54	3/8	100
12	11.0	21.5	8	9.5	16.0	27	27	62	1/2	170
15	12.5	23.0	10	16.0	22.0	36	30	69	3/4	250
19	12.5	23.0	10	16.0	22.0	36	30	72	3/4	270
25	12.5	25.5	12	21.8	28.0	41	36	89	1	370
32	15.5	30.5	13	27.0	36.0	50	46	114	1 1/4	780
38	16.5	33.5	14	31.8	42.0	55	50	128	1 1/2	1250
50	18.0	37.0	19	42.0	54.0	70	65	150	2	2200

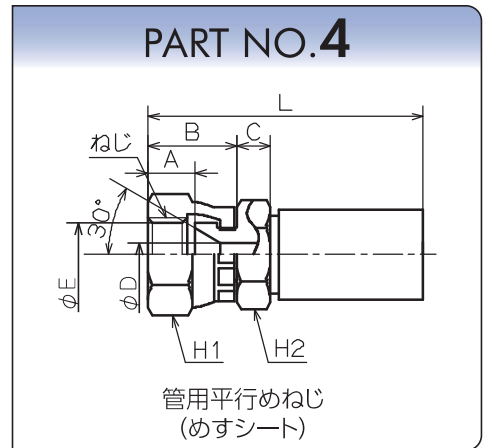

サイズ	A	B	C	D	E	H1	H2	L	ねじ G	概略重量g
6	5.5	16.0	6	4.2	7.5	19	19	51	1/4	70
9	6.5	19.0	6	7.0	10.0	22	22	54	3/8	100
12	8.5	21.5	8	9.5	13.0	27	27	62	1/2	170
15	9.0	23.0	10	16.0	19.0	36	30	69	3/4	250
19	9.0	23.0	10	16.1	19.0	36	30	72	3/4	270
25	9.5	25.5	12	21.8	24.0	41	36	89	1	370
32	12.5	30.5	13	27.0	32.0	50	46	114	1 1/4	780
38	12.5	33.5	14	31.8	38.0	55	50	128	1 1/2	1250
50	15.0	37.0	19	42.0	49.0	70	65	150	2	2200

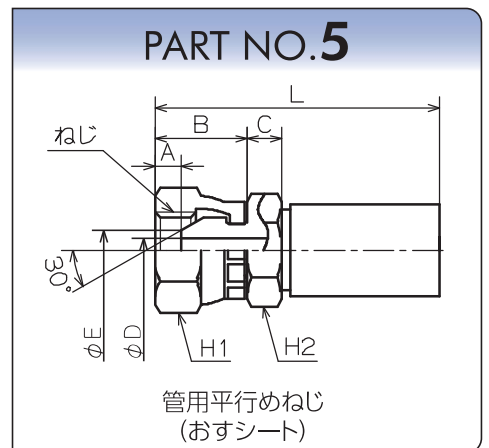

IBG 210

サイズ	A	D	E	F	H1	H2	J	L	ねじ G	概略 重量g
6	8.5	4.2	9.5	24	19	-	44	71	1/4	70
9	9.5	6.5	13.0	26	22	-	49	76	3/8	115
12	10.5	9.5	16.0	32	27	-	56	86	1/2	200
15	12.5	13.6	22.0	38	36	30	70	104	3/4	380
19	12.5	17.0	22.0	38	36	30	70	107	3/4	400
25	12.5	21.0	28.0	47	41	36	85	134	1	570

PART NO.454

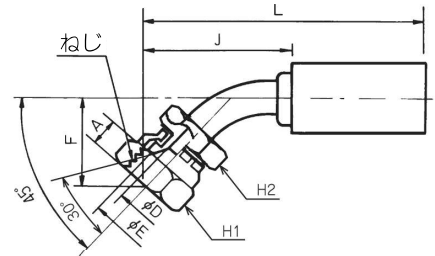

45° ベンドフィッティング
(めすシート)

サイズ	A	D	E	F	H1	H2	J	L	ねじ G	概略 重量g
6	8.5	4.2	9.5	44	19	-	26	53	1/4	70
9	9.5	6.5	13.0	47	22	-	34	61	3/8	125
12	10.5	9.5	16.0	55	27	-	37	67	1/2	200
15	12.5	13.6	22.0	70	36	30	50	84	3/4	420
19	12.5	17.0	22.0	70	36	30	50	87	3/4	440
25	12.5	21.0	28.0	87	41	36	68	117	1	680

PART NO.904

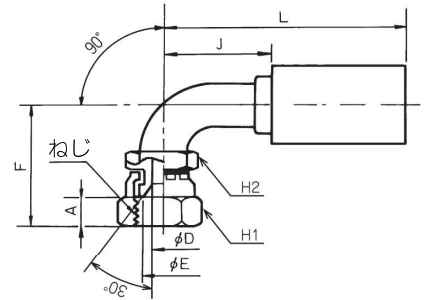

90° ベンドフィッティング
(めすシート)

サイズ	A	D	E	F	H1	H2	J	L	ねじ G	概略 重量g
6	4.5	4.2	7.0	24	19	-	44	71	1/4	70
9	5.5	6.5	9.7	26	22	-	49	76	3/8	115
12	7.0	9.5	13.0	32	27	-	56	86	1/2	200
15	9.0	13.6	19.0	38	36	30	70	104	3/4	380
19	9.0	17.0	19.0	38	36	30	70	107	3/4	400
25	9.5	21.0	24.0	47	41	36	85	134	1	570

PART NO.455

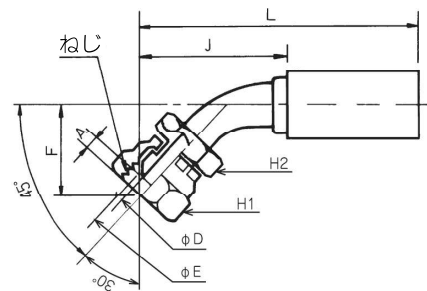

45° ベンドフィッティング
(おすシート)

サイズ	A	D	E	F	H1	H2	J	L	ねじ G	概略 重量g
6	4.5	4.2	7.0	44	19	-	26	53	1/4	70
9	5.5	6.5	9.7	47	22	-	34	61	3/8	125
12	7.0	9.5	13.0	55	27	-	37	67	1/2	200
15	9.0	13.6	19.0	70	36	30	50	84	3/4	420
19	9.0	17.0	19.0	70	36	30	50	87	3/4	440
25	9.5	21.0	24.0	87	41	36	68	117	1	680

PART NO.905

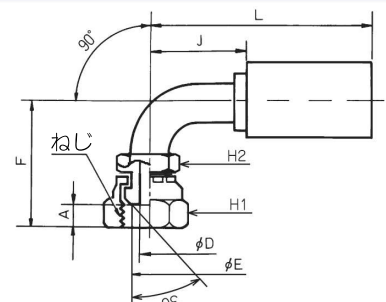

90° ベンドフィッティング
(おすシート)

IBG 210

サイズ	A	B	D	G	J	L				概略重量g
12	30.2	25.46	9.0	6.7	52	82				150
15	38.1	31.81	12.0	6.7	54	88				270
19	38.1	31.81	15.0	6.7	54	91				250
25	44.5	39.68	20.0	8.0	65	114				650
32	50.8	44.51	26.0	8.0	85	153				900
38	60.3	53.84	31.8	8.0	87	165				1500
50	71.4	63.37	42.0	9.5	101	193				2600
65	84.1	76.20	54.0	9.5	60	179				2900

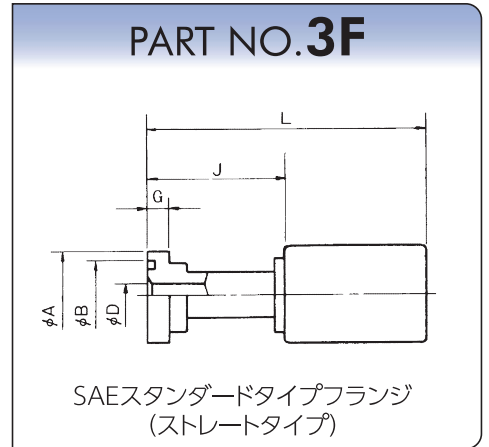

サイズ	A	B	D	F	G	J	L			概略重量g
12	30.2	25.46	10.5	22	6.7	51	81			160
15	38.1	31.81	13.6	26	6.7	64	98			280
19	38.1	31.81	17.0	26	6.7	64	101			300
25	44.5	39.68	21.0	28	8.0	76	125			550
32	50.8	44.51	27.0	32	8.0	91	159			700
38	60.3	53.84	32.5	52	8.0	140	218			1500
50	71.4	63.37	43.5	58	9.5	148	240			2800

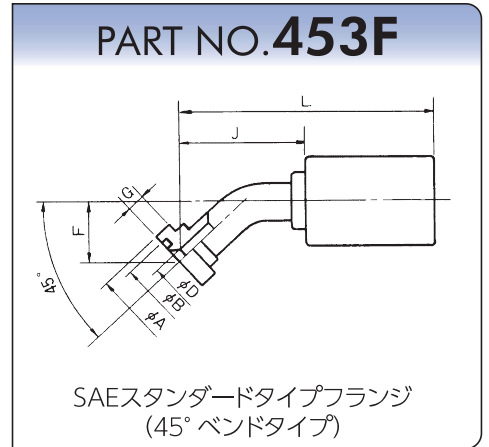

サイズ	A	B	D	F	G	J	L			概略重量g
12	30.2	25.46	10.5	43	6.7	52	82			180
15	38.1	31.81	13.6	56	6.7	50	84			280
19	38.1	31.81	17.0	56	6.7	50	87			300
25	44.5	39.68	21.0	63	8.0	76	125			700
32	50.8	44.51	27.0	71	8.0	91	159			1000
38	60.3	53.84	32.5	112	8.0	115	193			1800
50	71.4	63.37	43.5	127	9.5	140	232			3900
65	84.1	76.2	43.1	135	9.5	134	253			

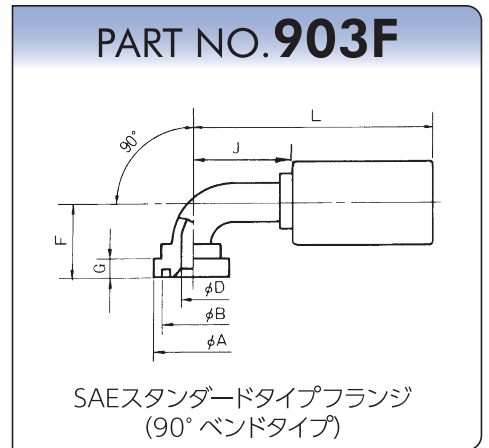

IBG 210

サイズ	A	B	C	D	E	F			L	重量g
6										
9										
12	63	40	22	30	11	16			72	750
15	63	40	22	30	11	16			76	800
19	68	45	22	35	11	20			78	900
25	80	53	28	40	13	25			97	1,650
32	90	63	28	45	13	31.5			121	2,300
38	100	70	36	55	18	37.5			139	3,200
50	112	80	36	65	18	47.5			168	4,700
65										

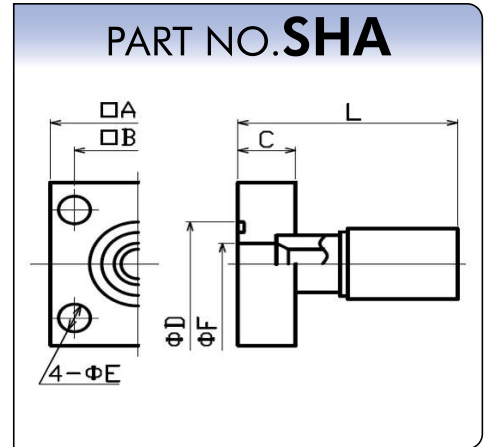

サイズ	A	B	C		E	F			L	重量g
6										
9										
12	63	40	22		11	16			72	750
15										
19	68	45	22		11	20			78	900
25	80	53	28		13	25			97	1,650
32	90	63	28		13	31.5			121	2,300
38	100	70	36		18	37.5			139	3,200
50	112	80	36		18	47.5			168	4,700
65										

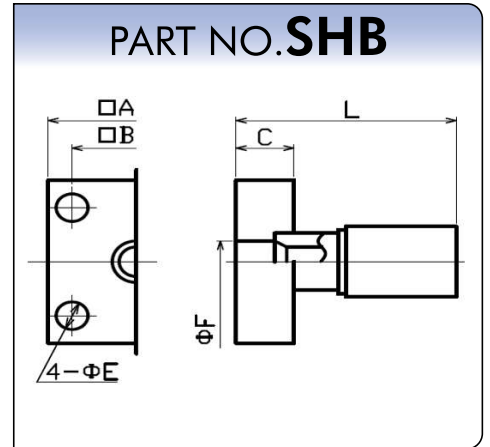

サイズ	A	B	C	D	E	F			L	重量g
6										
9										
12	54	36	22	30	11	16			72	550
15	54	36	22	30	11	16			76	600
19	58	40	22	35	11	20			78	700
25	68	48	28	40	13	25			97	1,350
32	76	56	28	45	13	31.5			121	1,700
38	92	65	36	55	18	37.5			139	2,900
50	100	73	36	65	18	47.5			168	4,100
65										

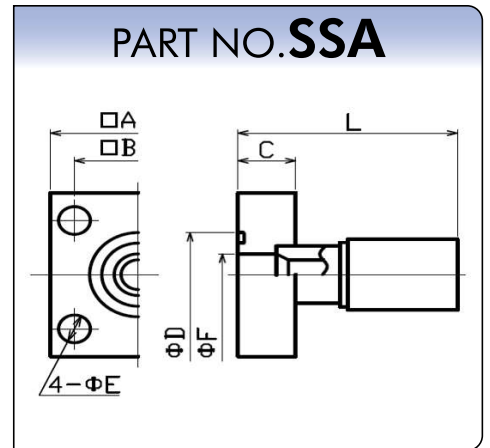

サイズ	A	B	C		E	F			L	重量g
6										
9										
12	54	36	22		M10	16			72	550
15	54	36	22		M10	16			76	600
19	58	40	22		M10	20			78	700
25	68	48	28		M12	25			97	1,350
32	76	56	28		M12	31.5			121	1,700
38	92	65	36		M16	37.5			139	2,900
50	100	73	36		M16	47.5			168	4,100
65										

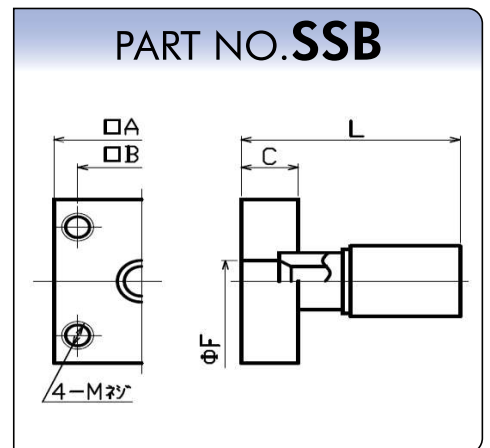

IBG 210

サイズ	A	B	C	D	E	F	G	H	L	重量g
6										
9										
12	63	40	22	30	11	16	2	36	74	750
15										
19	68	45	22	35	11	20	2	42.3	81	900
25	80	53	28	40	13	25	2	50	97	1,650
32	90	63	28	45	13	31.5	2	55	122	2,300
38	100	70	36	55	18	37.5	2	65	139	3,200
50	112	80	36	65	18	47.5	2	75	164	4,700
65										

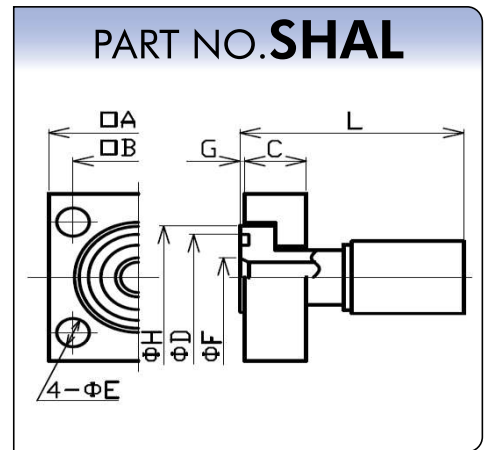

サイズ	A	B	C	E	F	G	H	L	重量g
6									
9									
12	63	40	22	11	16	2	36	74	750
15									
19	68	45	22	11	20	2	42.3	81	900
25	80	53	28	13	25	2	50	97	1,650
32	90	63	28	13	31.5	2	55	122	2,300
38	100	70	36	18	37.5	2	65	139	3,200
50	112	80	36	18	47.5	2	75	164	4,700
65									

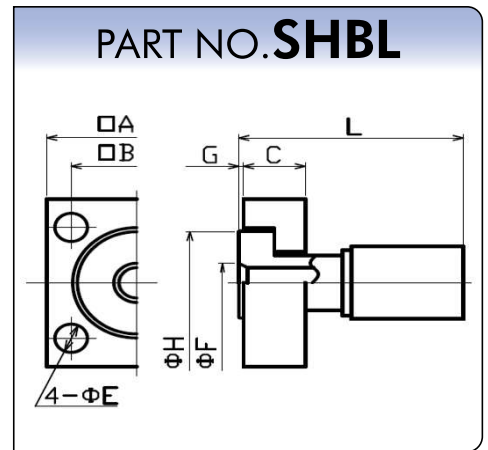

サイズ	A	B	C	D	E	F	G	H	L	重量g
6										
9										
12	54	36	22	30	11	16	2	36	74	550
15	54	36	22	30	11	16	2	36	78	600
19	58	40	22	35	11	20	2	42.3	81	700
25	68	48	28	40	13	25	2	50	97	1,350
32	76	56	28	45	13	31.5	2	55	122	1,700
38	92	65	36	55	18	37.5	2	65	139	2,900
50	100	73	36	65	18	47.5	2	75	164	4,100
65										

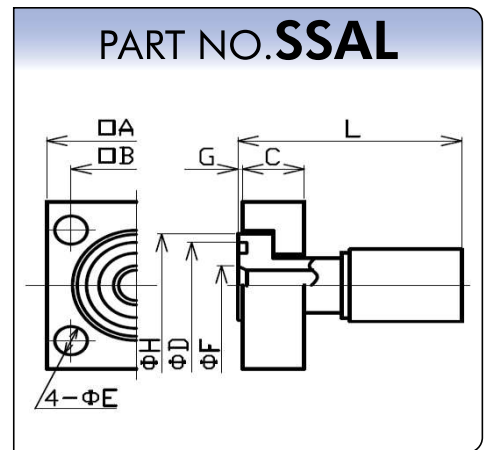

サイズ	A	B	C	E	F	G	H	L	重量g
6									
9									
12	54	36	22	M10	16	2	36	74	550
15									
19	58	40	22	M10	20	2	42.3	81	700
25	68	48	28	M12	25	2	50	97	1,350
32	76	56	28	M12	31.5	2	55	122	1,700
38	92	65	36	M16	37.5	2	65	139	2,900
50	100	73	36	M16	47.5	2	75	164	4,100
65									

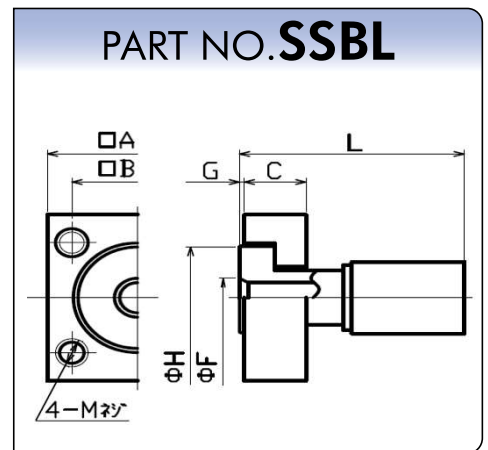

GRAN MAXシリーズ

IBG 280

構造

内面ゴム: 耐油性合成ゴム
補強層: 硬鋼線
外面ゴム: 耐油・耐候性合成ゴム

適用流体

一般鉱物系作動油

流体温度範囲

-40℃～+100℃

ホース構造・補強層

2W/B



IBG 280

サイズ	補強層	内径 mm	外径 mm	最高使用圧力 MPa	最小破壊圧力 MPa	最小曲げ半径 mm	概略重量 g/m
6	2W/B	6.3	14.0	28	112	70	330
9	2W/B	9.5	17.3	28	112	80	480
12	2W/B	12.7	21.0	28	112	90	600

IBG 280

サイズ	B	C	D	H	L				ねじ R	概略 重量g
6	13	6	4.2	17	48				1/4	50
9	15	6	7.0	22	50				3/8	90
12	18	8	9.5	27	58				1/2	150

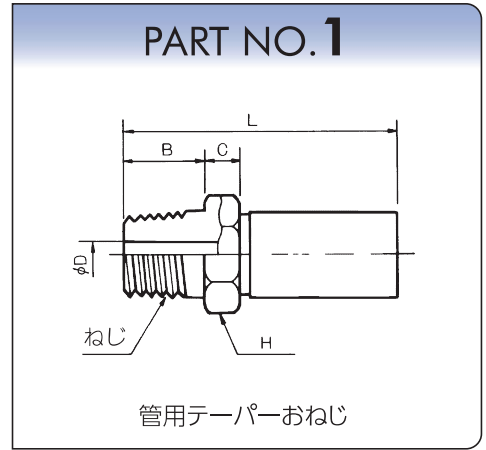

サイズ	B	C	D	E	H	L			ねじ G	概略 重量g
6	13	6	4.2	9.5	17	48			1/4	50
9	15	6	7.0	12.5	22	50			3/8	90
12	18	8	9.5	16.0	27	58			1/2	150

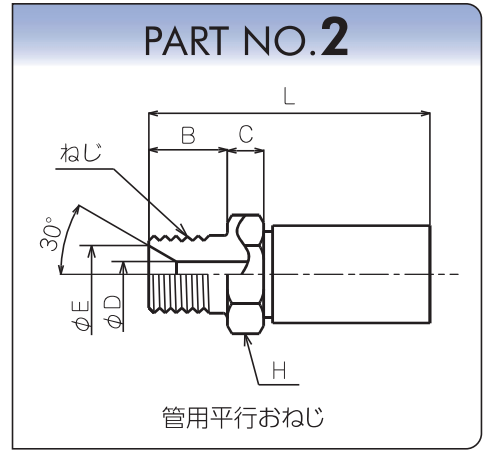

サイズ	A	B	C	D	E	H1	H2	L	ねじ G	概略 重量g
6	8.5	16.0	6	4.2	9.5	19	17	51	1/4	60
9	9.5	19.0	6	7.0	13.0	22	22	54	3/8	100
12	11.0	21.5	8	9.5	16.0	27	27	62	1/2	170

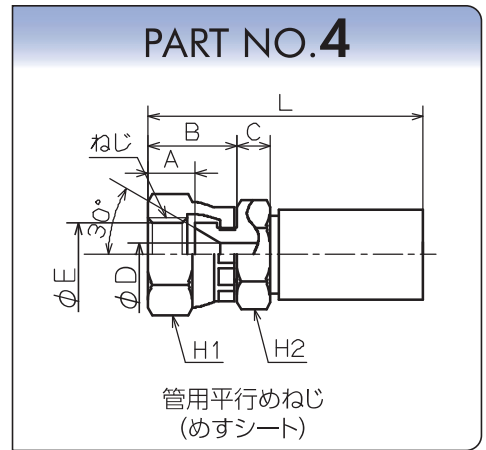

サイズ	A	B	C	D	E	H1	H2	L	ねじ G	概略 重量g
6	5.5	16.0	6	4.2	7.5	19	17	51	1/4	60
9	6.5	19.0	6	7.0	10.0	22	22	54	3/8	100
12	8.5	21.5	8	9.5	13.0	27	27	62	1/2	170

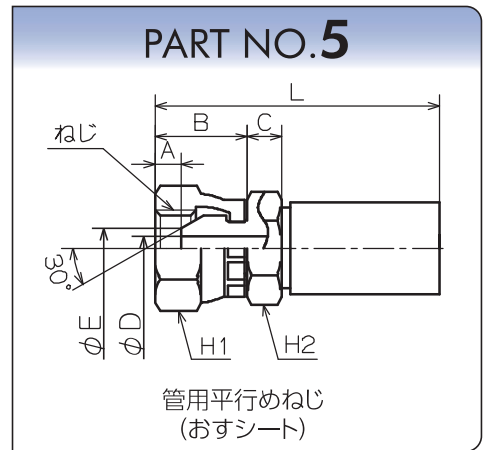

GRAN MAXシリーズ

IBG 280

サイズ	A	D	E	F	H1	H2	J	L	ねじ G	概略 重量g
6	8.5	4.2	9.5	24	19	-	44	71	1/4	70
9	9.5	6.5	13.0	26	22	-	49	76	3/8	115
12	10.5	9.5	16.0	32	27	-	56	86	1/2	200

PART NO.454

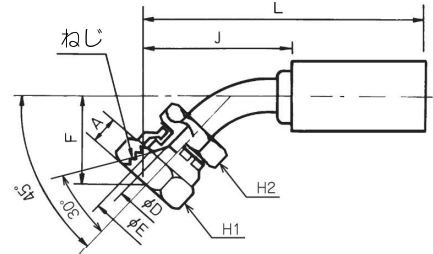

45° ベンドフィッティング
(めすシート)

サイズ	A	D	E	F	H1	H2	J	L	ねじ G	概略 重量g
6	8.5	4.2	9.5	44	19	-	26	53	1/4	70
9	9.5	6.5	13.0	47	22	-	34	61	3/8	125
12	10.5	9.5	16.0	55	27	-	37	67	1/2	200

PART NO.904

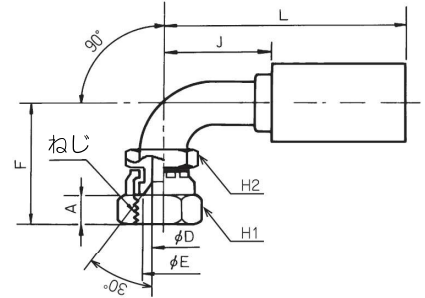

90° ベンドフィッティング
(めすシート)

サイズ	A	D	E	F	H1	H2	J	L	ねじ G	概略 重量g
6	4.5	4.2	7.0	24	19	-	44	71	1/4	70
9	5.5	6.5	9.7	26	22	-	49	76	3/8	115
12	7.0	9.5	13.0	32	27	-	56	86	1/2	200

PART NO.455

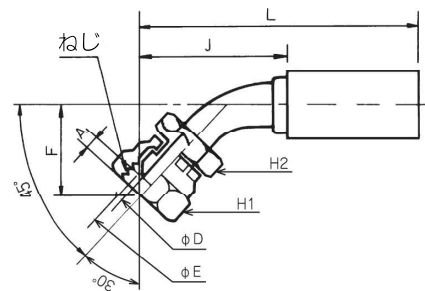

45° ベンドフィッティング
(おすシート)

サイズ	A	D	E	F	H1	H2	J	L	ねじ G	概略 重量g
6	4.5	4.2	7.0	44	19	-	26	53	1/4	70
9	5.5	6.5	9.7	47	22	-	34	61	3/8	125
12	7.0	9.5	13.0	55	27	-	37	67	1/2	200

PART NO.905

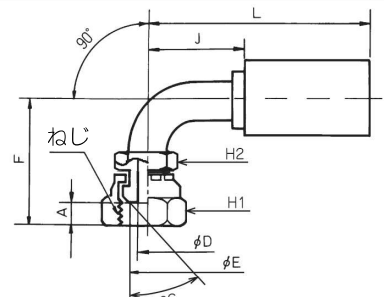

90° ベンドフィッティング
(おすシート)

GRAN MAXシリーズ

IBG 350

構造

内面ゴム: 耐油性合成ゴム
 補強層: 硬鋼線
 外面ゴム: 耐油・耐候性合成ゴム

適用流体

一般鉱物系作動油

流体温度範囲

-40℃～+100℃

ホース構造・補強層

2W/B



IBG 350

サイズ	補強層	内径 mm	外径 mm	最高使用圧力 MPa	最小破壊圧力 MPa	最小曲げ半径 mm	概略重量 g/m
6	2W/B	6.3	14.0	35	140	80	340
9	2W/B	9.5	17.7	35	140	110	500

IBG 350

サイズ	B	C	D	H	L				ねじ R	概略 重量g
6	13	6	4.2	17	48				1/4	50
9	15	6	7.0	22	50				3/8	90

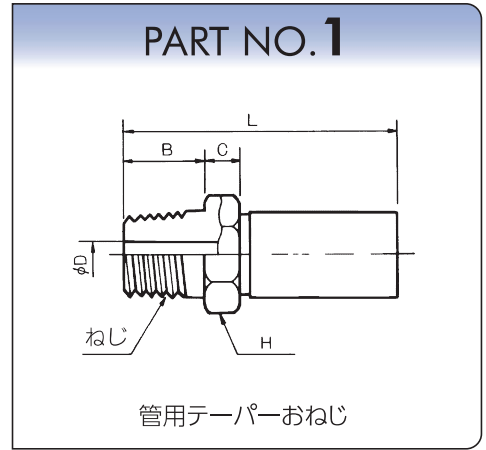

サイズ	B	C	D	E	H	L			ねじ G	概略 重量g
6	13	6	4.2	9.5	17	48			1/4	50
9	15	6	7.0	12.5	22	50			3/8	90

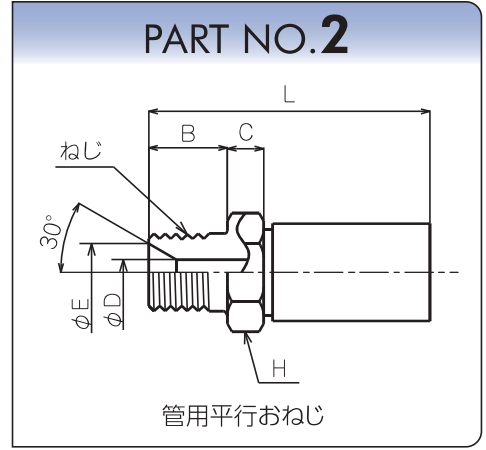

サイズ	A	B	C	D	E	H1	H2	L	ねじ G	概略 重量g
6	8.5	16.0	6	4.2	9.5	19	17	51	1/4	60
9	9.5	19.0	6	7.0	13.0	22	22	54	3/8	100

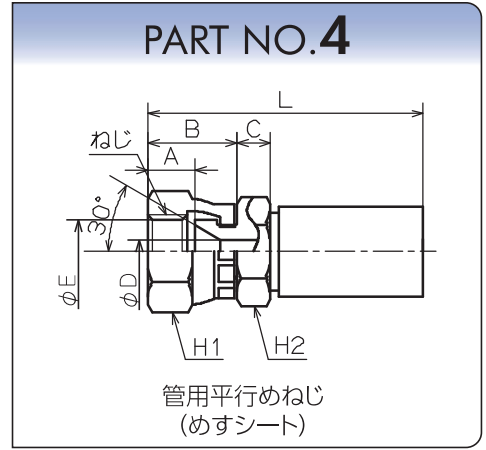

サイズ	A	B	C	D	E	H1	H2	L	ねじ G	概略 重量g
6	5.5	16.0	6	4.2	7.5	19	17	51	1/4	60
9	6.5	19.0	6	7.0	10.0	22	22	54	3/8	100

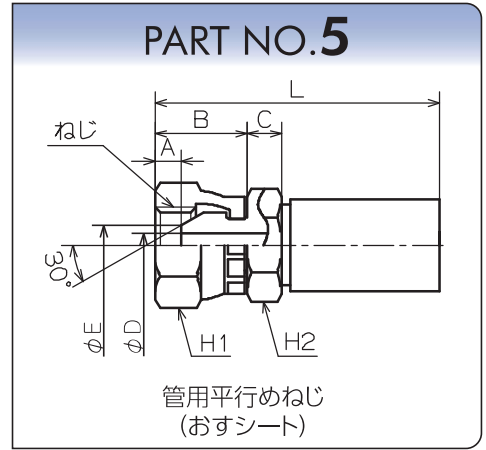

GRAN MAXシリーズ

IBG 350

サイズ	A	D	E	F	H1	H2	J	L	ねじ G	概略 重量g
6	8.5	4.2	9.5	24	19	-	44	71	1/4	70
9	9.5	6.5	13.0	26	22	-	49	76	3/8	115

PART NO.454

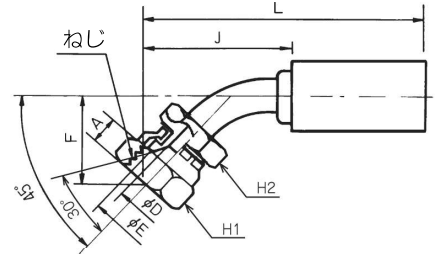

45° ベンドフィッティング
(めすシート)

サイズ	A	D	E	F	H1	H2	J	L	ねじ G	概略 重量g
6	8.5	4.2	9.5	44	19	-	26	53	1/4	70
9	9.5	6.5	13.0	47	22	-	34	61	3/8	125

PART NO.904

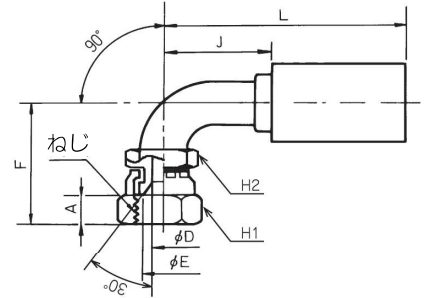

90° ベンドフィッティング
(めすシート)

サイズ	A	D	E	F	H1	H2	J	L	ねじ G	概略 重量g
6	4.5	4.2	7.0	24	19	-	44	71	1/4	70
9	5.5	6.5	9.7	26	22	-	49	76	3/8	115

PART NO.455

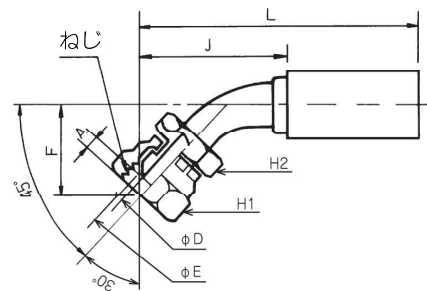

45° ベンドフィッティング
(おすシート)

サイズ	A	D	E	F	H1	H2	J	L	ねじ G	概略 重量g
6	4.5	4.2	7.0	44	19	-	26	53	1/4	70
9	5.5	6.5	9.7	47	22	-	34	61	3/8	125

PART NO.905

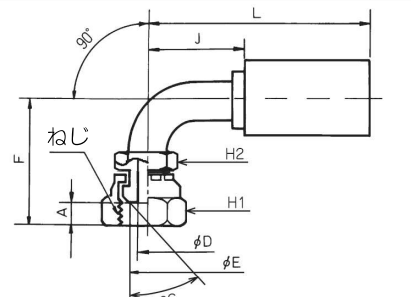

90° ベンドフィッティング
(おすシート)

M-GHD 280

構造

内面ゴム: 耐油性合成ゴム
 補強層: 硬鋼線
 外面ゴム: 耐摩・耐候性合成ゴム

適用流体

一般鉱物系作動油

流体温度範囲

-40℃～+120℃

ホース構造・補強層



M-GHD 280

サイズ	補強層	内径 mm	外径 mm	最高使用圧力 MPa	最小破壊圧力 MPa	最小曲げ半径 mm	概略重量 g/m
15	4W/S	15.9	26.6	28	112	140	970
19	4W/S	19.0	29.8	28	112	180	1120
25	4W/S	25.4	36.6	28	112	210	1490
32	4W/S	31.8	44.5	28	112	270	2500

M-GHD 280

サイズ	B	C	D	H	L				ねじ R	概略 重量g
15	20	11	16.0	30	77				3/4	250
19	20	11	16.0	30	89				3/4	300
25	22	12	21.0	36	100				1	500
32	25	13	27.0	46	108				1 1/4	720

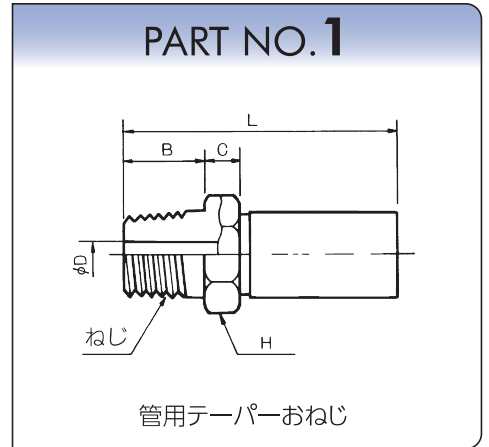

サイズ	B	C	D	E	H	L			ねじ G	概略 重量g
19	20	11	16.0	21.5	30	89			3/4	300
25	22	12	21.0	27.5	36	100			1	500
32	25	13	27.0	36.0	46	108			1 1/4	720

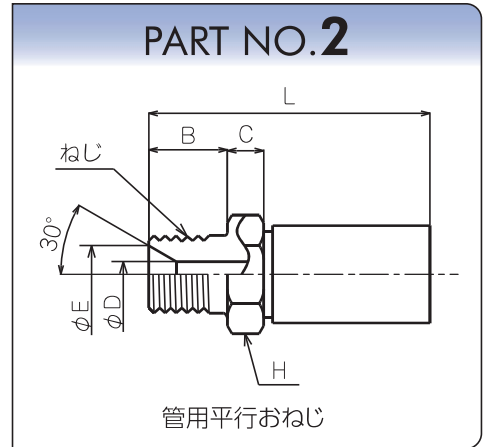

サイズ	A	B	C	D	E	H1	H2	L	ねじ G	概略 重量g
15	12.5	23.0	11	16.0	22.0	36	30	80	3/4	300
19	12.5	23.0	10	16.0	22.0	36	30	91	3/4	350
25	12.5	25.5	12	21.0	28.0	41	36	104	1	550
32	15.5	30.5	13	27.0	36.0	50	46	114	1 1/4	800

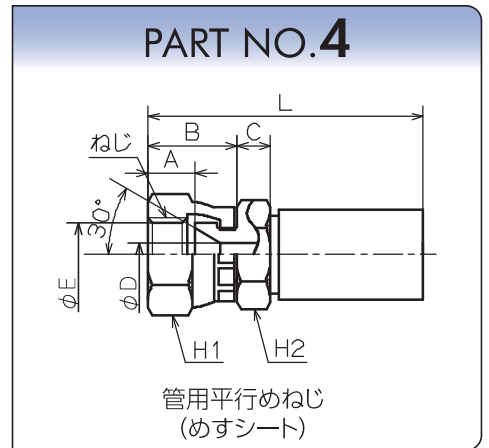

サイズ	A	B	C	D	E	H1	H2	L	ねじ G	概略 重量g
15	9.0	23.0	11	16.0	19.0	36	30	80	3/4	300
19	9.0	23.0	10	16.0	19.0	36	30	91	3/4	350
25	9.5	25.5	12	21.0	24.0	41	36	104	1	550
32	12.5	30.5	13	27.0	32.0	50	46	114	1 1/4	800

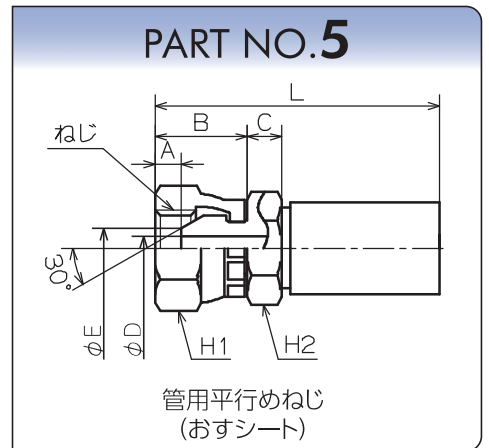

M-GHD 280

サイズ	A	D	E	F	H1	H2	J	L	ねじ G	概略 重量g
15	12.5	13.6	22.0	38	36	30	70	114	3/4	400
19	12.5	17.0	22.0	38	36	30	76	133	3/4	450
25	12.5	21.0	28.0	47	41	36	85	149	1	750

PART NO.454

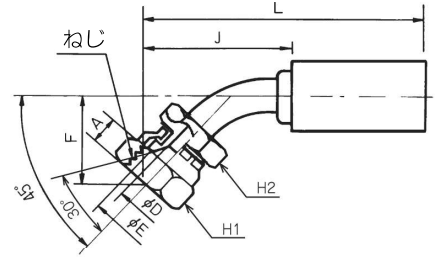

45° ベンドフィッティング
(めすシート)

サイズ	A	D	E	F	H1	H2	J	L	ねじ G	概略 重量g
15	12.5	13.6	22.0	70	36	30	64	108	3/4	440
19	12.5	17.0	22.0	70	36	30	64	121	3/4	500
25	12.5	21.0	28.0	87	41	36	68	132	1	820

PART NO.904

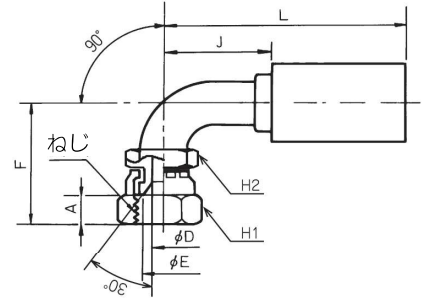

90° ベンドフィッティング
(めすシート)

サイズ	A	D	E	F	H1	H2	J	L	ねじ G	概略 重量g
15	9.0	13.6	19.0	38	36	30	70	114	3/4	400
19	9.0	17.0	19.0	38	36	30	76	133	3/4	450
25	9.5	21.0	24.0	47	41	36	85	149	1	750

PART NO.455

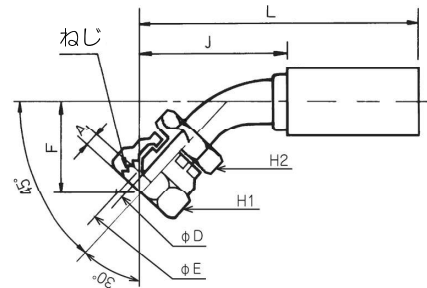

45° ベンドフィッティング
(おすシート)

サイズ	A	D	E	F	H1	H2	J	L	ねじ G	概略 重量g
15	9.0	13.6	19.0	70	36	30	64	108	3/4	440
19	9.0	17.0	19.0	70	36	-	64	120	3/4	500
25	9.5	21.0	24.0	87	41	36	68	132	1	820

PART NO.905

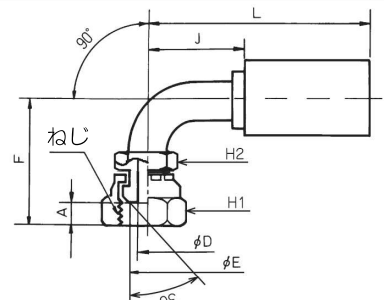

90° ベンドフィッティング
(おすシート)

M-GHD 280

サイズ	A	B	D	G	J	L				概略重量g
15	41.3	31.81	16.0	8.75	54	98				300
19	41.3	31.81	17.0	8.75	54	111				355
25	47.6	39.68	20.0	9.5	65	129				620
32	54.0	44.51	26.0	10.3	71	139				920

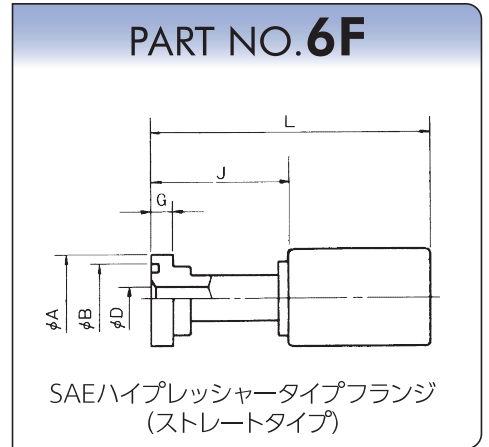

サイズ	A	B	D	F	G	J	L			概略重量g
15	41.3	31.81	13.6	27	8.75	65	109			310
19	41.3	31.81	17.0	27	8.75	74	131			400
25	47.6	39.68	21.0	34	9.5	78	142			665
32	54.0	44.51	27.0	40	10.3	94	162			910

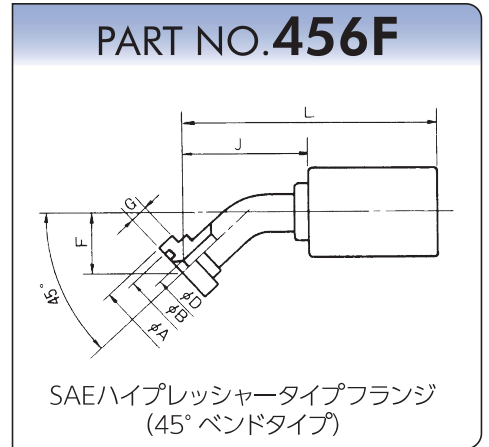

サイズ	A	B	D	F	G	J	L			概略重量g
15	41.3	31.81	13.6	56	8.75	64	108			350
19	41.3	31.81	17.0	56	8.75	66	123			435
25	47.6	39.68	21.0	65	9.5	76	140			745
32	54.0	44.51	27.0	74	10.3	91	159			1020

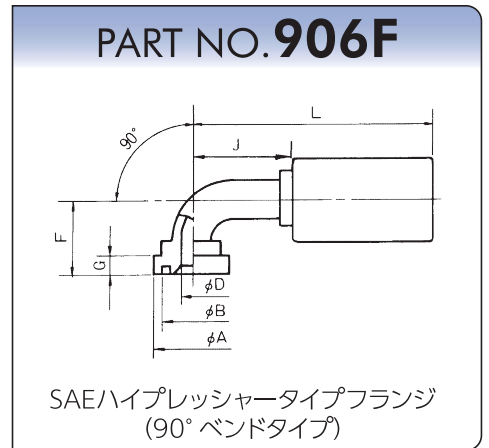

※タイプとは当該規格と互換性があることを表します。

M-GHD 350

構造

内面ゴム: 耐油性合成ゴム
 補強層: 硬鋼線
 外面ゴム: 耐摩・耐候性合成ゴム

適用流体

一般鉱物系作動油

流体温度範囲

-40℃～+120℃

ホース構造・補強層



M-GHD 350

サイズ	補強層	内径 mm	外径 mm	最高使用圧力 MPa	最小破壊圧力 MPa	最小曲げ半径 mm	概略重量 g/m
12	4W/S	12.7	22.9	35	140	135	750
15	4W/S	15.9	26.6	35	140	160	990
19	4W/S	19.0	29.8	35	140	190	1160
25	4W/S	25.4	37.1	35	140	240	1730

M-GHD 350

サイズ	B	C	D	H	L				ねじ R	概略 重量g
12	18	8	10.5	27	71	1/2				190
15	20	11	16.0	30	77	3/4				250
19	20	11	16.0	30	89	3/4				300
25	22	12	21.0	36	100	1				500

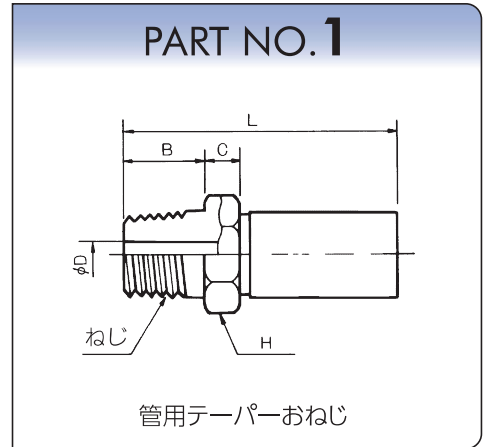

サイズ	B	C	D	E	H	L			ねじ G	概略 重量g
12	18	8	10.5	16	27	71	1/2			190
19	20	11	16.0	21.5	30	89	3/4			300
25	22	12	21.0	27.5	36	100	1			500

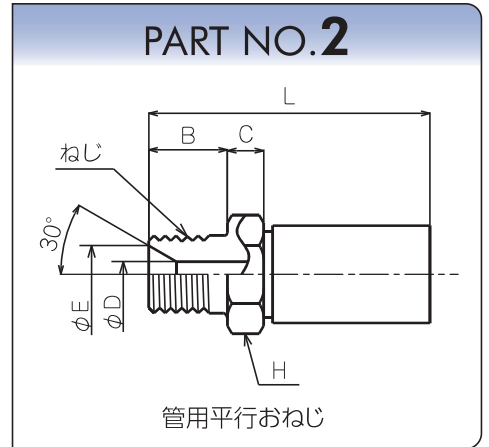

サイズ	A	B	C	D	E	H1	H2	L	ねじ G	概略 重量g
12	11.0	21.5	8	9.5	16.0	27	27	75	1/2	215
15	12.5	23.0	11	16.0	22.0	36	30	80	3/4	300
19	12.5	23.0	10	16.0	22.0	36	30	91	3/4	350
25	12.5	25.5	12	21.0	28.0	41	36	104	1	550

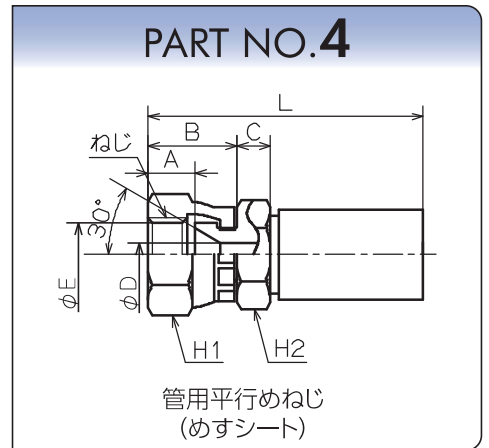

サイズ	A	B	C	D	E	H1	H2	L	ねじ G	概略 重量g
12	8.5	21.5	8	9.5	13.0	27	27	75	1/2	215
15	9.0	23.0	11	16.0	19.0	36	30	80	3/4	300
19	9.0	23.0	10	16.0	19.0	36	30	91	3/4	350
25	9.5	25.5	12	21.0	24.0	41	36	104	1	550

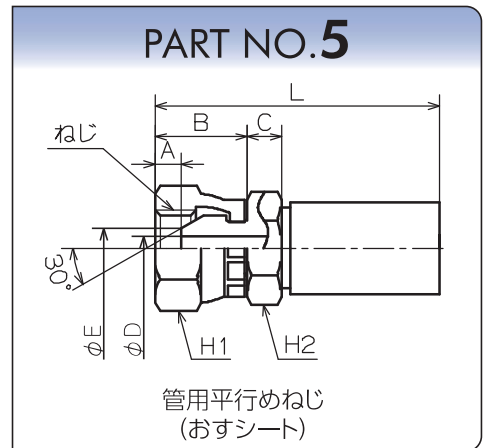

M-GHD 350

サイズ	A	D	E	F	H1	H2	J	L	ねじ G	概略 重量g
12	10.5	10.5	16.0	34	27	—	62	105	1/2	280
15	12.5	13.6	22.0	38	36	30	70	114	3/4	400
19	12.5	17.0	22.0	38	36	30	76	133	3/4	450
25	12.5	21.0	28.0	47	41	36	85	149	1	750

PART NO.454

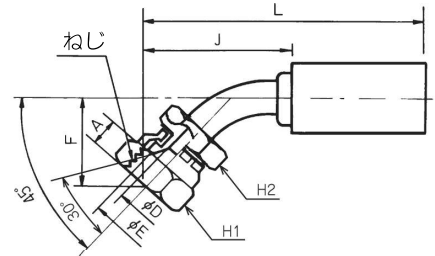

45° ベンドフィッティング
(めすシート)

サイズ	A	D	E	F	H1	H2	J	L	ねじ G	概略 重量g
12	10.5	10.5	16.0	59	27	—	51	94	1/2	270
15	12.5	13.6	22.0	70	36	30	64	108	3/4	440
19	12.5	17.0	22.0	70	36	30	64	121	3/4	500
25	12.5	21.0	28.0	87	41	36	68	132	1	820

PART NO.904

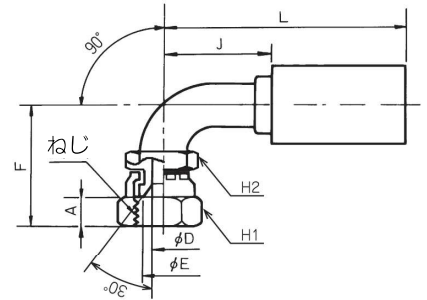

90° ベンドフィッティング
(めすシート)

サイズ	A	D	E	F	H1	H2	J	L	ねじ G	概略 重量g
12	7.0	9.5	13.0	34	27	—	62	105	1/2	280
15	9.0	13.6	19.0	38	36	30	70	114	3/4	400
19	9.0	17.0	19.0	38	36	30	76	133	3/4	450
25	9.5	21.0	24.0	47	41	36	85	149	1	750

PART NO.455

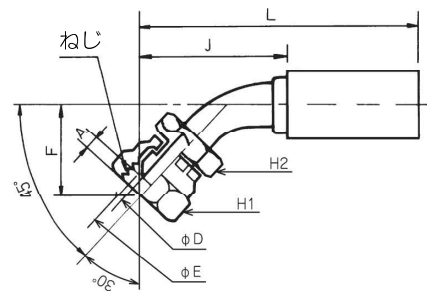

45° ベンドフィッティング
(おすシート)

サイズ	A	D	E	F	H1	H2	J	L	ねじ G	概略 重量g
12	7.0	9.5	13.0	59	27	—	51	94	1/2	270
15	9.0	13.6	19.0	70	36	30	64	108	3/4	440
19	9.0	17.0	19.0	70	36	—	64	121	3/4	500
25	9.5	21.0	24.0	87	41	36	68	132	1	820

PART NO.905

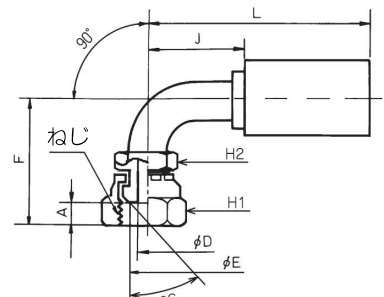

90° ベンドフィッティング
(おすシート)

M-GHD 350

サイズ	A	B	D	G	J	L				概略重量g
12	31.8	25.46	9.0	7.75	52	95				210
15	41.3	31.81	16.0	8.75	54	98				300
19	41.3	31.81	17.0	8.75	54	111				355
25	47.6	39.68	20.0	9.5	65	129				620

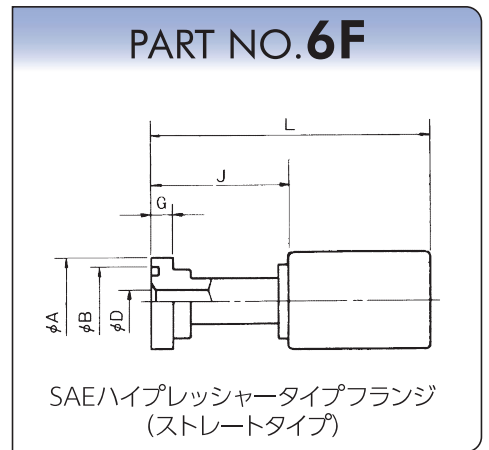

サイズ	A	B	D	F	G	J	L			概略重量g
12	31.8	25.46	10.5	23	7.75	52	95			220
15	41.3	31.81	13.6	27	8.75	65	109			310
19	41.3	31.81	17.0	27	8.75	74	131			400
25	47.6	39.68	21.0	34	9.5	78	142			665

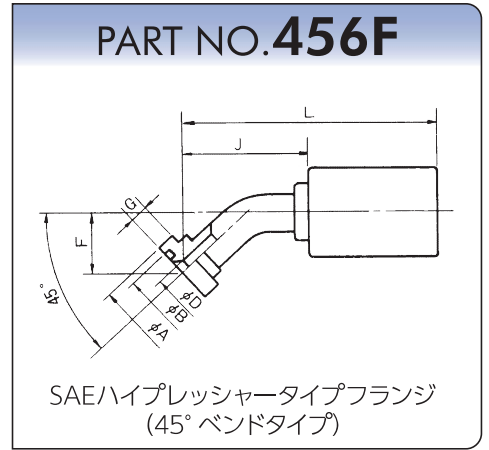

サイズ	A	B	D	F	G	J	L			概略重量g
12	31.8	25.46	10.5	45	7.75	52	95			240
15	41.3	31.81	13.6	56	8.75	64	108			350
19	41.3	31.81	17.0	56	8.75	66	123			435
25	47.6	39.68	21.0	65	9.5	76	140			745

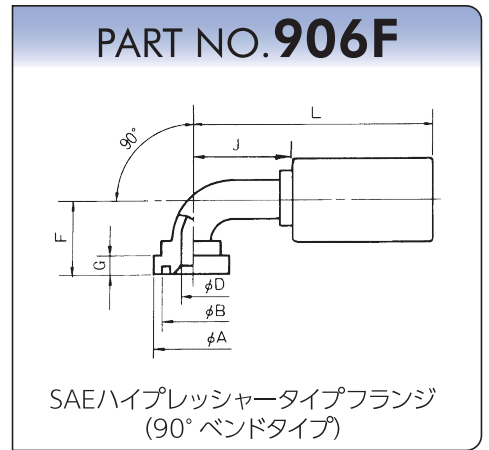

※タイプとは当該規格と互換性があることを表します。

M-GHD 420

構造

内面ゴム: 耐油性合成ゴム
 補強層: 硬鋼線
 外面ゴム: 耐油・耐候性合成ゴム

適用流体

一般鉱物系作動油

流体温度範囲

-40℃～+100℃

ホース構造・補強層

4W/S

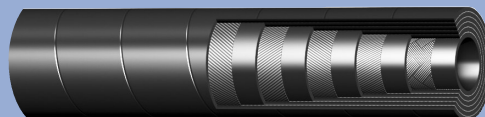

6W/S

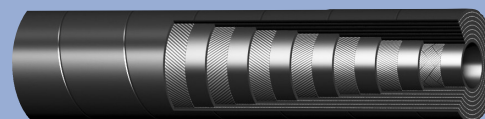

M-GHD 420

サイズ	補強層	内径 mm	外径 mm	最高使用圧力 MPa	最小破壊圧力 MPa	最小曲げ半径 mm	概略重量 g/m
19	4W/S	19.0	30.1	42	168	200	1330
25	4W/S	25.4	37.5	42	168	240	1950
32	6W/S	31.8	49.7	42	168	330	3830

※金具については、弊社・代理店までお問い合わせください。